

intersystems

Automatic Filling Systems

9575 N 109th Ave Omaha, NE 68142
402.330.1500 Fax 402.330.3350
www.intersystems.net

MODEL ABP-55

The model ABP-55 is designed to provide accurate, subsurface, semi-automatic liquid filling of 55 gallon drums.

Velcon subsurface fillers provide a unique programmable product level tracking system to minimize foaming, reduce drips and maintain a clean lance.

The model ABP-55 has a robust 304 stainless steel structural construction and 316 stainless steel wetted parts. It incorporates an Allen Bradley PLC and HMI based VFC1100 control system. It has built in safety features to guarantee a safe clean and accurate filling.

Standard Features

- General purpose Non-Hazardous area electrical classification
- VFC1100 controller Hardware
 - Allen Bradley Micrologix PLC with Ethernet IP
 - Allen Bradley PanelView-Plus 400 Graphical user interface with Ethernet IP
 - 24V DC controls
- Software
 - User friendly menu driven system
 - Recipe programming and saving of all fill set points
 - Slow-Fast-Slow fill mode programming
 - Automatic Preact calculation
 - Resume capability to continue filling aborted fill cycles
 - No Drum No fill feature to prevent product spillage
 - Flow rate monitoring
 - Cycle time monitoring
 - Net weight Over/Under fill monitoring
 - System Alarm display plus historian
 - Weight indicator control, Zero, Tare, Gross/Net
 - See VFC1100 controller manual for full standard features
- Air motor and ball screw driven SUB-SURFACE FILL RAISE BY WEIGHT SYSTEM. This system will fill in subsurface mode keeping the lance at programmable position. Filling using this method eliminates foaming and keeps the lance clean.
- Two ball valve system for Slow-Fast-Slow fill modes
- Hand operated lever for Fill Start/Stop operation

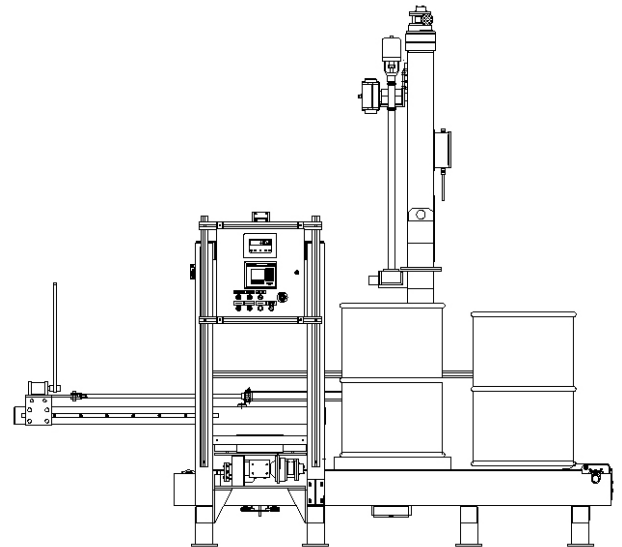

Standard Construction

- 304 stainless steel structural construction
- 316 stainless steel wetted parts (Lance and pipe).
- Powder coated carbon steel control NEMA-4 enclosures
- Two piece 316 stainless steel ball valves
- Foot valve at end of lance for minimizing drips
- Gravity weighed stainless steel drip cup
- Fume collection hood with sight glass and 2" hose connection
- Teflon seals and seats
- Sealed bearings and cam followers
- Carbon steel ball screw drive system
- Stainless Steel Weigh Plate
 - Rising Platform
 - Sealed load cell
 - 1 part in 5,000 resolution (1,000 Lb X 0.2 LB)
 - 1,000 LB capacity

Available Options

1. Electrical area classification Options
 - Class-I Division-I area package
 - Class-I Division-II area package
2. Controller Options
 - Upgrade to PanelView-Plus 600 Color
3. Environmental area Options
 - Corrosive area package
4. Lance Options
 - Sanitary Lance
 - Corrosive
 - Quick Disconnect
5. Enclosure Options
 - Stainless steel
6. Structural Options
 - Dual Lance
 - Hinged wiper ring housing
7. Pneumatic Drip-pan
8. Purge through lance rod/alignment cone
9. Container grounding and monitoring
10. Overfill detection
11. Weighted container seal fume collector
12. Accessories
 - Bung tooling
 - Work platform
 - Line voltage regulator
 - Step-down transformer
 - Serial Printer
 - Spare parts
13. Conveyor
 - Complete Conveyor line available to complete your System

Sequence of Operation

- Operator programs VFC1100 for fill presets in program mode and switches to run mode and turns the system on.
- System is ready for a fill cycle and displays “Ready To Fill”
- Once a drum is detected at the entry and of the system (The rake station) the rake arm is lowered and the drum rake is energized raking the drum in to the bung positioning station.
- Once a drum is detected at the bung positioning station, the drum clamp is engaged centering the drum on the chain.
- The drum rotate motor is energized rotating the drum while monitoring for the bung opening.
- Once the opening is located the bung positioner cone is lowered precisely positioning the bung opening 30” from the fill lance.
- The chain conveyor is energized moving the drum 30” to locate it under the fill lance.
- Once the drum is detected at the fill station the weight plate is raised lifting the drum for filling.
- Controller checks for presence of container on scale and automatically tares the container weight. If container is not detected (this is accomplished by checking the weight on the scale) the cycle is aborted automatically and an error message is displayed on the PanelView plus screen.
- The lance is lowered to the bottom of the container while monitoring lance misalignment.
- System opens the foot valve and ball valves.
- System starts the fill cycle in slow fill mode until the start slow fill target weight is met.
- System switches to fast fill mode until the final slow fill target weight is met.
- System switches to slow fill mode until target weight is met.
- The lance will raise by weight tracking the product level during the entire fill cycle.
- System closes the foot valve and ball valve.
- System starts raising the lance to the top position.
- System delays for settling delay time to give product to settle down.
- System recalculates Preact value.
- System sends fill data through the serial port on the PanelView Plus.
- The weight plate is lowered placing the drum on the chain conveyor.
- The chain conveyor is energized moving the drum from the fill station to the manual bung insertion station.