

intersystems

Automatic Filling Systems

9575 N 109th Ave Omaha, NE 68142

402.330.1500 Fax 402.330.3350

www.intersystems.net

MODEL AIOT-55

The model AIOT-55 has a robust 304 stainless steel structural construction and 316 stainless steel wetted parts. It incorporates an Allen Bradley PLC and HMI based VFC1100 control system. It has built in safety features to guarantee a safe clean and accurate automatic filling of palletized, open top 55 gallon drums and totes.

Standard Features

- General purpose Non-Hazardous area electrical classification
- VFC1100 controller Hardware
 - Allen Bradley Micrologix PLC with Ethernet IP
 - Allen Bradley PanelView-Plus 400 Graphical user interface with Ethernet IP
 - 24V DC controls
- Software
 - User friendly menu driven system
 - Recipe programming and saving of all fill set points
 - Slow-Fast-Slow fill mode programming
 - Automatic Preact calculation
 - Resume capability to continue filling aborted fill cycles
 - No Drum No fill feature to prevent product spillage
 - Flow rate monitoring
 - Cycle time monitoring
 - Net weight Over/Under fill monitoring
 - System Alarm display plus historian
 - Weight indicator control, Zero, Tare, Gross/Net
 - See VFC1100 controller manual for full standard features
- Air motor and ball screw driven SUB-SURFACE FILL RAISE BY WEIGHT SYSTEM. This system will fill in subsurface mode keeping the lance at programmable position. Filling using this method eliminates foaming and keeps the lance clean.
- Two ball valve system for Slow-Fast-Slow fill modes
- Hand operated lever for Fill Start/Stop operation

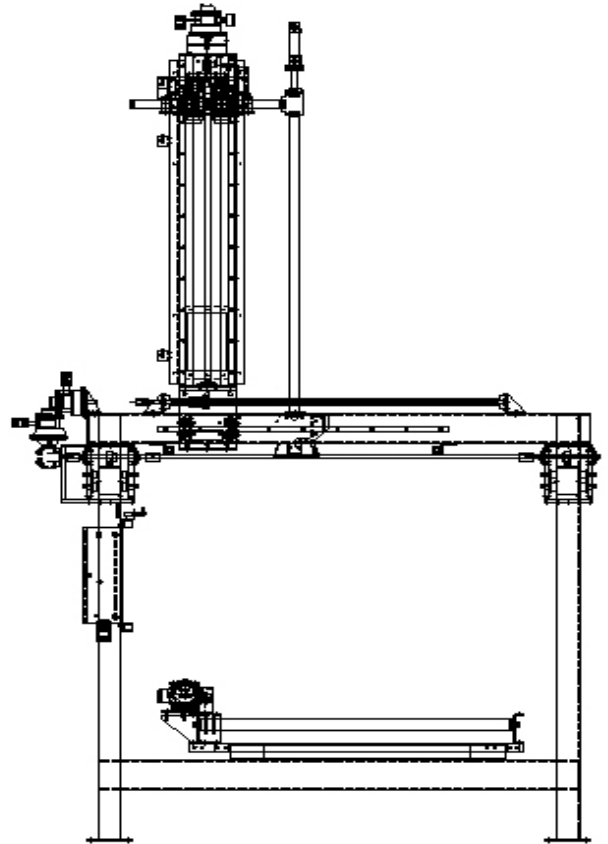

Standard Construction

- 304 stainless steel structural construction
- 316 stainless steel wetted parts (Lance and pipe).
- Powder coated carbon steel control NEMA-4 enclosures
- Two piece 316 stainless steel ball valves
- Foot valve at end of lance for minimizing drips
- Gravity weighed stainless steel drip cup
- Fume collection hood with sight glass and 2" hose connection
- Teflon seals and seats
- Sealed bearings and cam followers
- Carbon steel ball screw drive system
- Stainless Steel Weigh Plate
 - Sealed load cell
 - 1 part in 5,000 resolution
 - 5000 LB capacity

Available Options

1. Electrical area classification Options
 - Class-I Division-I area package
 - Class-I Division-II area package
2. Controller Options
 - Upgrade to PanelView-Plus 600 Color
3. Environmental area Options
 - Corrosive area package
4. Lance Options
 - Sanitary Lance
 - Corrosive
 - Quick Disconnect
5. Enclosure Options
 - Stainless steel
6. Structural Options
 - Dual Lance
 - Hinged wiper ring housing
7. Pneumatic Drip-pan
8. Purge through lance rod/alignment cone
9. Container grounding and monitoring
10. Overfill detection
11. Weighted container seal fume collector
12. Accessories
 - Bung tooling
 - Work platform
 - Line voltage regulator
 - Step-down transformer
 - Serial Printer
 - Spare parts
13. Conveyor
 - Complete Conveyor line available to complete your System

Sequence of Operation

- Operator programs VFC1100 for fill presets in program mode and switches to run mode
- System is ready for a fill cycle and displays "Ready To Fill"
- Operator moves the pallet onto the scale.
- The Operator presses a fill start push button
- Lance moves to fill position number 1.
- Controller checks for presence of container on scale and automatically tares the container weight. If container is not detected (this is accomplished by checking the weight on the scale) the cycle is aborted automatically and an error message is displayed on the PanelView plus screen.
- The lance is lowered close to the bottom of the container, monitoring for lance misalignment.
- System opens the foot valve and ball valves
- System starts the fill cycle in slow fill mode until the pre-fill target weight is met.
- System switches to fast fill mode, raising the lance with the product, until the dribble fill weight is met
- System switches to slow fill mode until target weight is met.
- System closes the foot valve and ball valve.
- System starts raising the lance to the top position.
- System delays for settling delay time to give product to settle down.
- System recalculates Preact value.
- System sends fill data through the serial port on the PanelView Plus.
- The carriage drive system moves the lance assembly to the next container and the cycle repeats
- Once all four containers are filled, the carriage drive will return to home position
- System is ready to fill next pallet of containers.