

# PRODUCTS & SYSTEMS

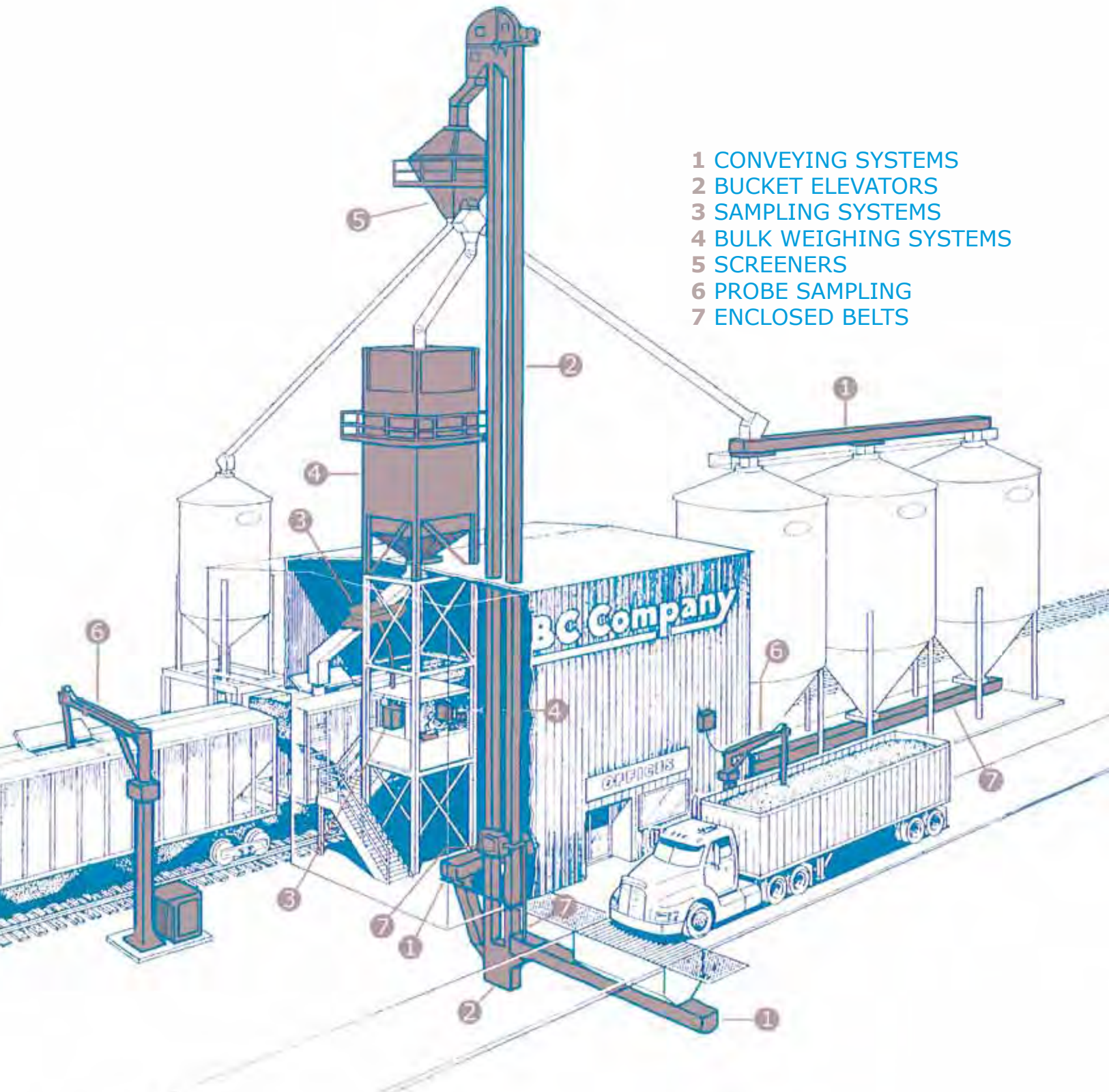

- 1 CONVEYING SYSTEMS
- 2 BUCKET ELEVATORS
- 3 SAMPLING SYSTEMS
- 4 BULK WEIGHING SYSTEMS
- 5 SCREENERS
- 6 PROBE SAMPLING
- 7 ENCLOSED BELTS

intersystems

Engineered Material Handling Solutions



## CONVEYING

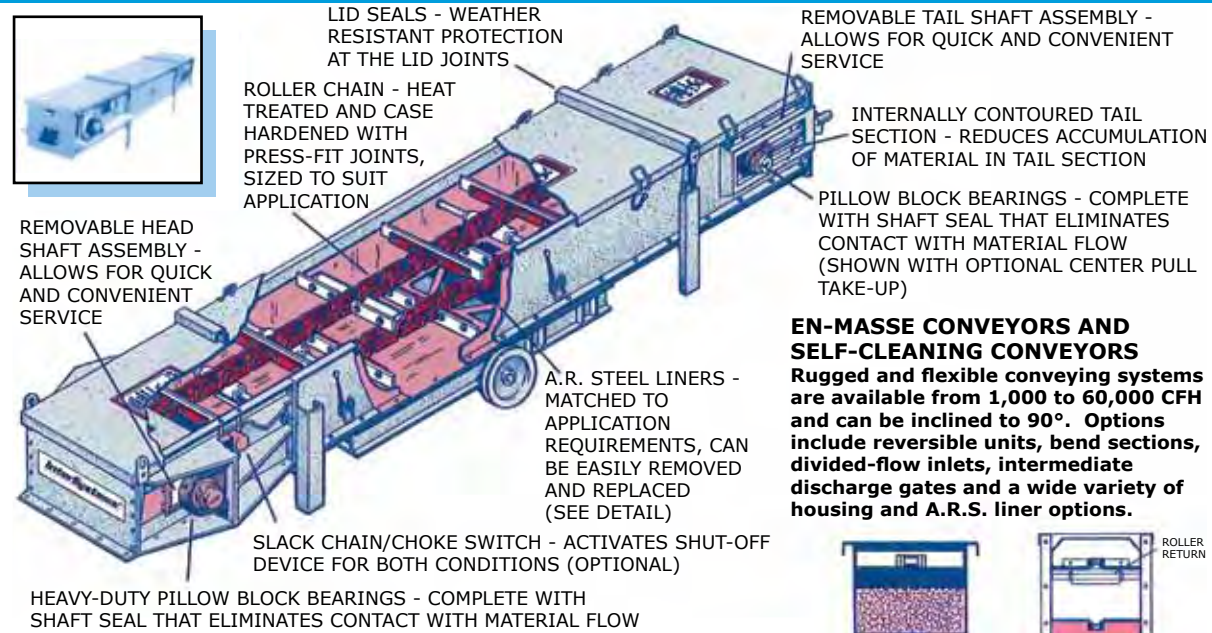

### SERVING THESE INDUSTRIES AND MORE...

- WOOD CHIPS
  - PETROCHEMICALS
  - ORE-AGGREGATE
  - CHEMICALS
  - PLASTICS
  - CEMENT
  - COAL
  - CERAMICS
  - MALT
  - SUGAR
  - FERTILIZER
- FOOD PRODUCTS
  - PROCESSING
  - PHARMACEUTICALS
  - SPECIALTY CHEMICALS
  - MINERALS
  - PULP & PAPER
  - MILLING
  - ANIMAL FEEDS
  - GRAINS
  - SALT
  - ETHANOL

## SAMPLING

Intersystems has led the industry with the most models, innovations and experience. Models are available for belt end, mid-belt, gravity chutes, bin wall, auger bottom, pneumatic lines (up/down/side flow) and more. Most products, including liquids, slurries, granulars, powders, lumps, chips and pellets can be sampled.

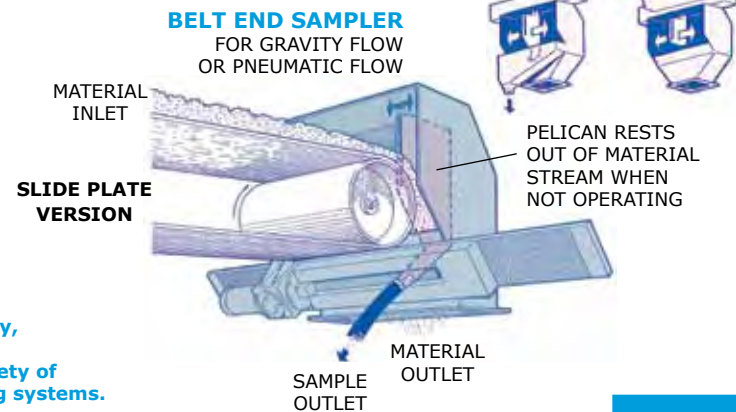
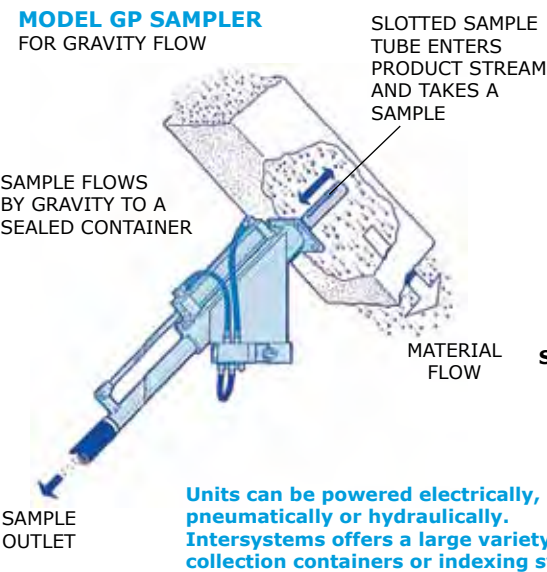
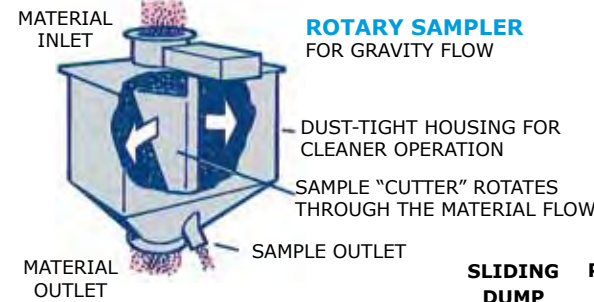
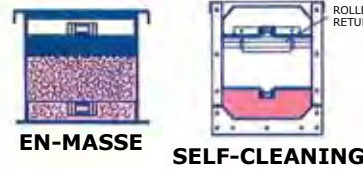

## ELEVATING

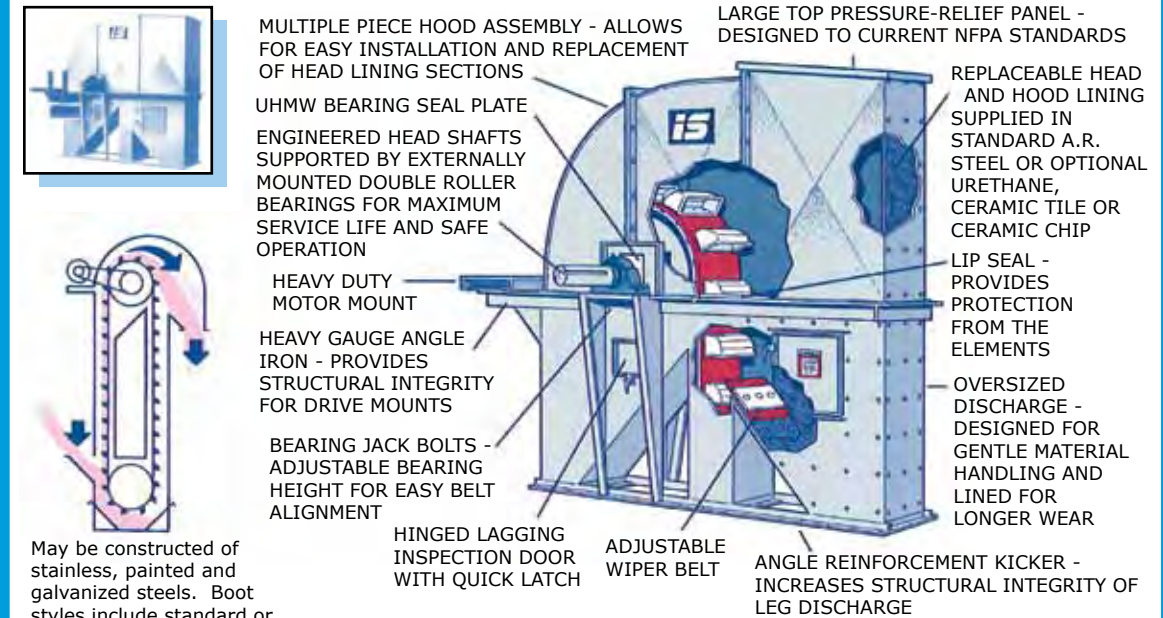

Elevators are designed and built for rugged duty, long service life and gentle handling of the material. Capacities from 1,000 to 100,000 CFH. Options include ladder/cage/platform systems, motion and alignment sensors, various drives, belt and cup styles.

## BULK WEIGHING

Factory assembled systems are available from 1,000 to 100,000 CFH and are prewired, preplumbed and preconfigured. Installation is simple and quick.

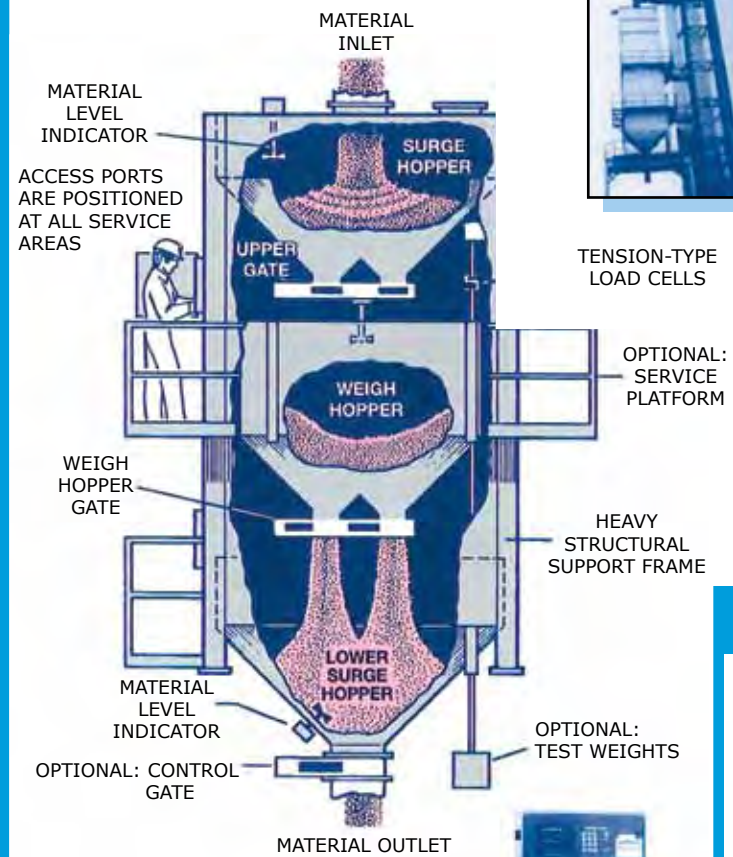

**BULK WEIGHING CONTROLS**  
 This state-of-the-art computerized control system features active color display, menu driven operation, car readers, a wide variety of printer options, programmable keys to operate other equipment, power-loss protection, manual backup controls, self diagnostic and self trimming. The unit can be linked to a host computer and can also be used to upgrade an existing weighing system.

## PROBE SAMPLING

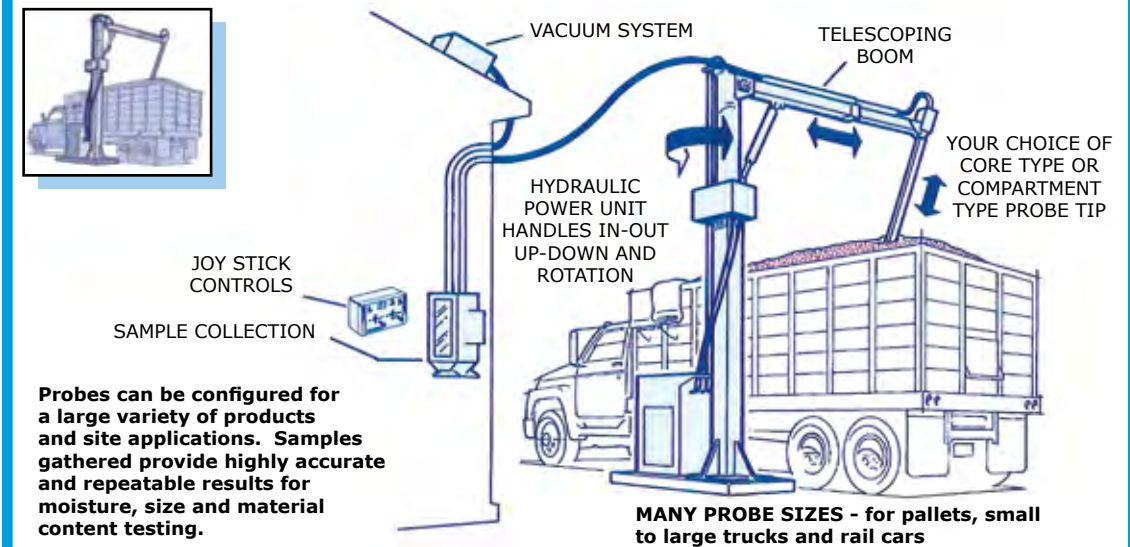

Probes can be configured for a large variety of products and site applications. Samples gathered provide highly accurate and repeatable results for moisture, size and material content testing.

## ENCLOSED BELT CONVEYING

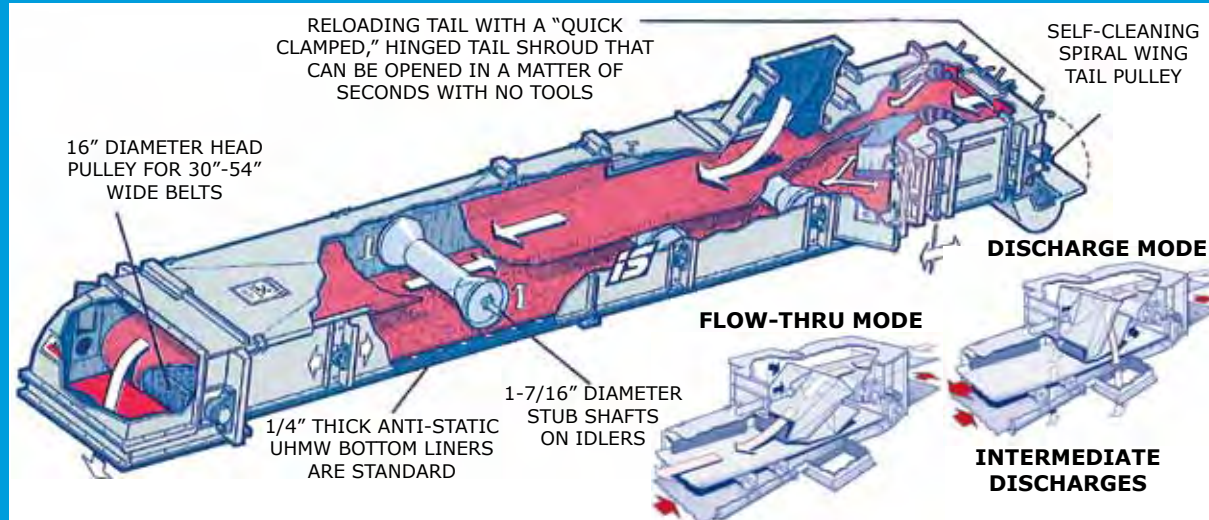

With the patented, internal proportional by-pass, Intersystems screeners are simply the best gravity-flow systems available. These rugged units are efficient, reliable and inexpensive. Capacities to 50,000 CFH.

### MATERIAL FLOW DIAGRAMS

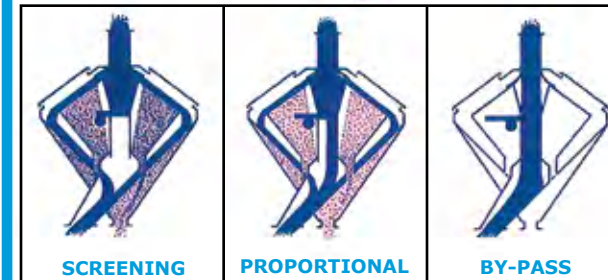

## SCREENING

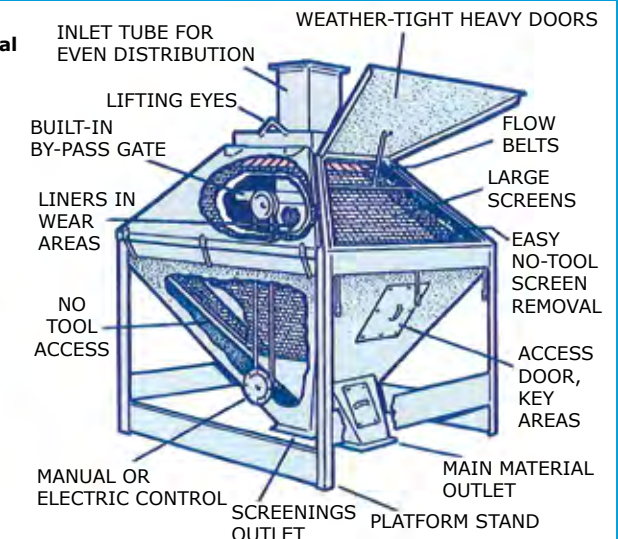



Intersystems reaches a worldwide market and numerous industries with expertise in the engineer and manufacture of bulk material handling products, industrial sampling systems and automatic filling and conveying systems. Intersystems is based in Omaha, Nebraska and in 2009 moved into a new state-of-the-art 140,000 square foot manufacturing facility.

Intersystems is ISO 9001 certified.



**intersystems**

9575 N 109<sup>th</sup> Ave  
Omaha, NE 68142 USA  
402.330.1500/800.228.1483  
Fax 402.330.3350  
bulkmatl@intersystems.net  
[www.intersystems.net](http://www.intersystems.net)